

# WA-TPC1771

17" Touch Panel Computer with  
600/5,000 Tags WebAccess

NEW



WebAccess



## Features

- Bundled with Advantech WebAccess, browser based HMI/SCADA software
- Intel® Atom™ D525 1.8 GHz processor
- 17" SXGA TFT LED LCD
- Compact design with die-cast Al front bezel
- Fanless cooling system
- IP65 compliant front panel
- PCIe and Mini PCIe expansion support
- 8 DI/O and backup SRAM support
- Supports DDR3 SDRAM
- Serial port isolation protection
- Automatic data flow control RS-485
- Gigabit Ethernet supported
- Built-in Windows® 7 embedded
- Supports external antenna for wireless communication

## Introduction

Advantech WA-TPC1771 is a plug and play HMI/SCADA server. It is built on Advantech solid Touch Panel Computer platform with pre-installed WebAccess SCADA software and pre-configured Windows 7 embedded and IIS environment. Just plug-in the power and network cable, the web enabled browser-based server is ready for user to start configuring his SCADA system from his computer. This HMI/SCADA server enables users to view real-time graphics, alarms, trending and logs, and control the field devices locally with the high quality 17" TFT LCD screen or via a web browser remotely on his desktop or notebook computer. The 1.8 GHz Intel® Atom™ D525 processor is the powerhouse of the server. It provides excellent computing power and balanced with it low power consumption. The fan-less design and spindle-free storage make this SCADA server a durable and reliable platform.

## WebAccess Version 7.1 Professional

- **I/O Tag Number** 600/5000
- **Internal Tag Number** 600/5000
- **Web Client** 1024
- **Alarm Logs** 5000
- **Action Logs** 5000
- **Graphics** Unlimited Number of Graphic Pages, Global Tag Source
- **Number of Data Logging** Number of I/O Tags License x 2
- **Web-Enabled Integration** Video and Google Maps
- **Others** SCADA Redundancy  
TclScript / VBScript / Jscript Language  
Data Transfer and Reporting  
ODBC and SQL Query  
Device Redundancy

## Specifications

### General

- **Operating System** Windows 7 Embedded
- **BIOS** AMI 8Mbit
- **Certification** BSMI, CCC, CE, FCC Class A, UL
- **Cooling System** Fanless Design
- **Enclosure** Front bezel: Die-cast Aluminum alloy  
Back housing: PC/ABS Resin
- **Mounting** Desktop, Wall or Panel Mount
- **Power Consumption** 24 W (typical)
- **Power Input** 10~29 V<sub>DC</sub>
- **Watchdog Timer** 1 ~ 255 sec (system)

### System Hardware

- **CPU** Intel® Atom™ D525 1.8 GHz with 1MB cache
- **Chipset** ICH8M
- **Memory** 4GB SO-DIMM DDR3 SDRAM
- **LAN** 10/100/1000Base-T x 2
- **Expansion Slots** Half-size PCI-E or full-size Mini PCI-E
- **Storage** 2.5" SATA, 1TB 5400RPM
- **I/O** RS-232 x 2 (COM1, 2) with isolation  
RS-422/485 x 1 (COM3) with isolation and auto data flow control  
USB 2.0 x 2 (Host)  
PS/2 x 1
- **DI/DO & Backup SRAM** 8 x DI/DO with isolation and backup 1MB SRAM

### LCD Display

- **Display Type** SXGA TFT LED LCD
- **Display Size** 17"
- **Max. Resolution** 1280 x 1024

### Touchscreen

- **Lifespan** 36 million touches at single point
- **Light Transmission** Above 75%
- **Resolution** Linearity
- **Type** 5-wire, analog resistive

### Environment

- **Humidity** 10 ~ 95% RH @ 40°C, non-condensing
- **Ingress Protection** Front panel: NEMA4, IP65
- **Operating Temperature** 0 ~ 50°C (32 ~ 122°F)
- **Storage Temperature** -20 ~ 60°C (-4 ~ 140°F)
- **Vibration Protection** With HDD: 1 Grms (5 ~ 500 Hz)  
(Operating, random vibration)

## Dimensions

Unit: mm

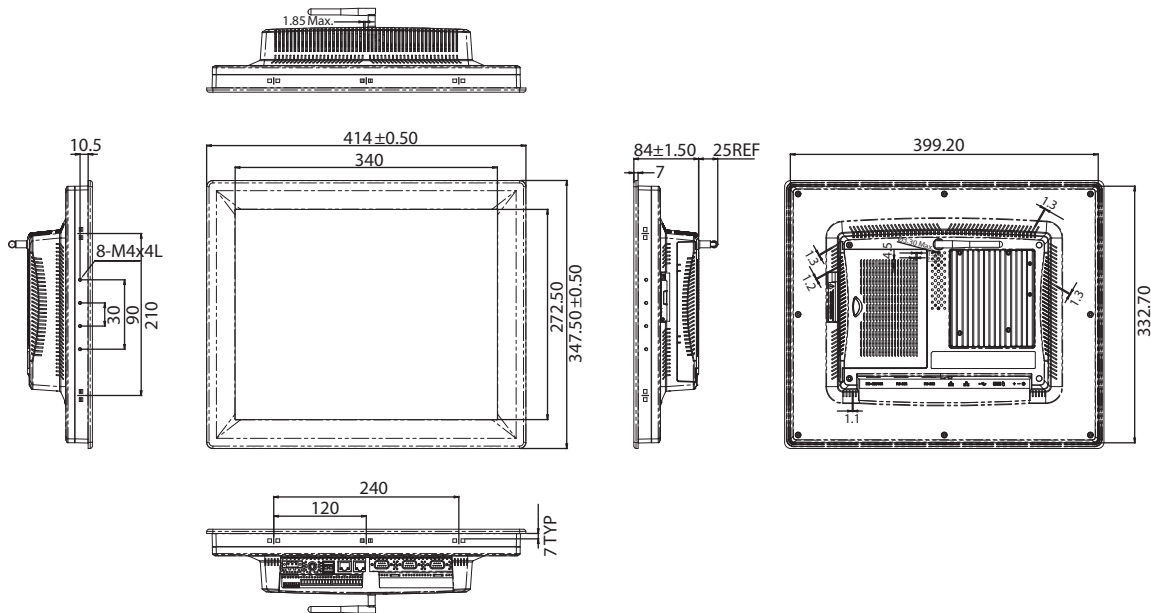

**Panel Cut-out Dimensions: 400.8±1 x 334.3 ±1mm (16.03" x 13.37")**

## Ordering Information

- **WA-TPC1771-T600E** 17" Touch Panel Computer, 600 tags WebAccess with Traditional Chinese
- **WA-TPC1771-T50HE** 17" Touch Panel Computer, 5,000 tags WebAccess with Traditional Chinese
- **WA-TPC1771-C600E** 17" Touch Panel Computer, 600 tags WebAccess with Simplified Chinese
- **WA-TPC1771-C50HE** 17" Touch Panel Computer, 5,000 tags WebAccess with Simplified Chinese
- **WA-TPC1771-E600E** 17" Touch Panel Computer, 600 tags WebAccess with English
- **WA-TPC1771-E50HE** 17" Touch Panel Computer, 5,000 tags WebAccess with English

### Accessories

- **TPC-1000H-WMKE** TPC series wallmount kit from 10" to 17"
- **TPC-1000H-SMKE** TPC series stand kit from 10" to 17"
- **1757003463** 100-240V<sub>ac</sub> to 19V<sub>dc</sub> 90W Power Adapter
- **1700001524** Power Cord 3P UL 10A 125V 1.8M
- **1702002605** Power cable EU Plug 1.8M
- **1702031801** Power cable UK Plug 1.8M
- **1702031836** Power cable China/Australia Plug 1.8M
- **EWM-W139F01E** 802.11 b/g/n, RT5390, 1T1R, Full-size Mini-PCIe
- **PWR-247-AE** 50W DC 24V/2.3A Output Power Supply
- **1750000318** EMI Antenna 2DBI 2.4GHz SMA CONN for ARK-3384
- **1750003222** 802.11b/g 5dBi Dipole Antenna
- **1750003418** Wireless Antenna AN2400-5901RS R/P SMA.M9dB

\* VESA support via a wall mounting kit

## Rear View

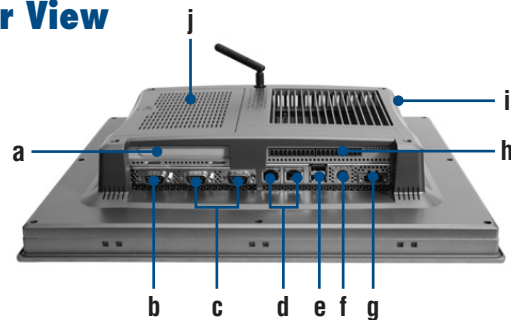

- a. PCI-E slot
- b. COM (RS-422/485)
- c. COM (RS-232)
- d. LAN (10/100/1000)
- e. USB 2.0
- f. PS/2
- g. Power Receptor
- h. DI/O ports
- i. CompactFlash
- j. Mini PCI-E slot